

Direct Pure | Direct Pure Water System, U

Generates ultrapure and RO water from tap water, producing up to 45 liters of RO-purified water per hour.

The upgraded Direct Pure water system offers greater convenience in every aspect of use, including enhanced process control, data traceability, and assured performance.

This system is manufactured in our production facility, which is registered under the ISO 9001, ISO 14001, ISO 45001 and ISO 50001 standards. Additionally, It is CE and RoHS certified.



Direct Pure U

Direct Pure U Extended

Key Features

Reliable water quality

- Stable RO permeability over a wide range of temperatures
- Diversion to drain if quality of RO permeate falls below set-point
- Automatic hourly recirculation of ultrapure water
- On-line TOC measurement based on complete oxidation methodology

Data traceability

- Automatic data backup for up to 2 years
- Easy data transfer via multiple interfaces, including LAN, USB

Low running cost

- High-efficiency cartridges and energy-efficient components
- All-in-one design. Space-Saver

Designed for Pure Simplicity

Easy to use

- An intuitive touchscreen menu allows you to easily access to real-time water quality monitoring, manual and volumetric dispensing, adjustable flow rates, and system alerts
- Quick installation. Simple maintenance and upkeep
- Placement flexibility

Environmentally friendly

- A mercury-free 265 nm germicidal UV lamp
- Digital and paperless data management
- Manufactured using green energy sources



Specifications

Parameter	Direct-Pure U	
Electrical specifications		
Operating voltage	24 VDC	
Input voltage	100 - 240 VAC	
Main system power	< 190 W	
Feed Water Requirements		
Conductivity / TDS	< 2000 μ S/cm @ 25 °C / < 1000 ppm	
Temperature	5 - 35 °C (41 - 95 F)	
Pressure	1.0 - 6.0 bar (15 - 90 psi)	
Product Water Type	Ultrapure water & RO water	
Dimensions & Weight		
Dimensions W x D x H	with 10 L tank	414 x 422 x 624 mm (16.3 x 16.6 x 24.5 in)
	w/o 10 L tank	414 x 310 x 624 mm (16.3 x 12.2 x 24.5 in)
Weight	net	21 kg
	gross	30 kg

Water Quality Compliance Quality of ultrapure water meets or exceeds ASTM, CLSI, CAP and ISO Type I water standards.

Product Water Quality	Direct-Pure U
RO water	
Flow rate	24, 45 L/hr
Conductivity (@ 25 °C)	Typically < 20 μ S/cm
RO rejection	97 - 98% ionic rejection (new RO cartridge), > 99% organic rejection, > 99% particulates & bacteria rejection
Ultrapure water	
Dispenser rate	Up to 2 L/min
Resistivity (@ 25 °C)	18.2 M Ω ·cm
TOC*	< 5 ppb
Particles (> 0.2 μ m)**	No particles with size > 0.2 μ m
Microorganisms**	< 0.001 cfu/ml
Pyrogens (endotoxins)***	< 0.001 Eu/ml
RNase***	< 0.5 pg/ml
DNase***	< 10 pg/ml

* Under appropriate operating conditions.

** with a 0.2 μ m final filter

*** with a RephiBio filter

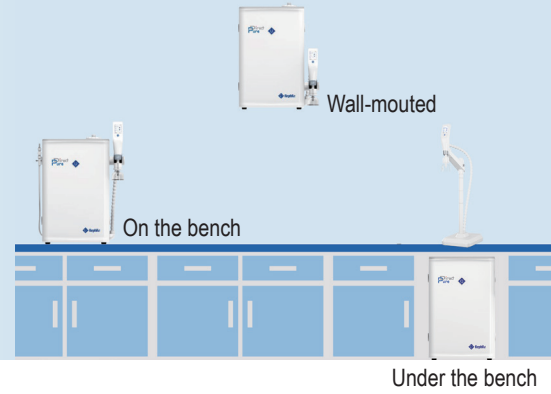
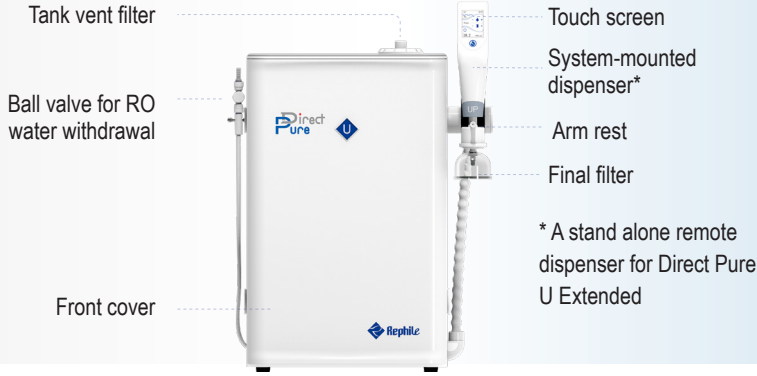

Cartridges

- High pressure rated housings
- Double O-ring sealing
- Color-coded labels
- Clear identification markings



Final filter

- 0.2 µm PES high flux capsule filter
- RephiBio filter for pyrogen-, nuclease-, protease- and bacteria-free water
- Final filters from other suppliers



Storage tank

- A 10-liter integrated HDPE tank
- Scalable to 30/60/100/350 liters
- Equipped with a tank sanitization module



Remote dispenser

- For Direct Pure U Extended
- 3-meter away from the system
- Height-adjustable
- 360 degree rotatable

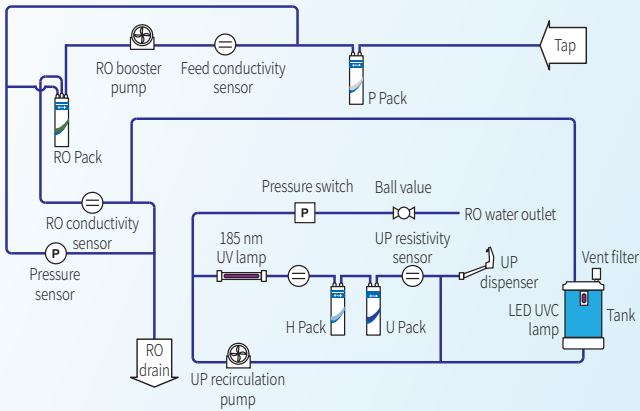

Description	Cat. No.
Direct Pure water system, U 24 set	RSOU02000K
Direct Pure water system, U 24 set, with 10L tank	RSOU0200TK
Direct Pure water system, U 45 set	RSOU04000K
Direct Pure water system, U 45 set, with 10L tank	RSOU0400TK
Direct Pure water system, U 24 Extended set	RSOUP2000K
Direct Pure water system, U 24 Extended set, with 10L tank	RSOUP200TK
Direct Pure water system, U 45 Extended set	RSOUP4000K
Direct Pure water system, U 45 Extended set, with 10L tank	RSOUP400TK
Direct Pure water system, U 24 TOC set	RSOU020T0K
Direct Pure water system, U 24 TOC set, with 10L tank	RSOU020TTK
Direct Pure water system, U 45 TOC set	RSOU040T0K
Direct Pure water system, U 45 TOC set, with 10L tank	RSOU040TTK
Direct Pure water system, U 24 TOC Extended set	RSOUP20T0K
Direct Pure water system, U 24 TOC Extended set, with 10L tank	RSOUP20TTK
Direct Pure water system, U 45 TOC Extended set	RSOUP40T0K
Direct Pure water system, U 45 TOC Extended set, with 10L tank	RSOUP40TTK

All rights reserved © 2026 RephiLe Bioscience, Ltd.
RephiLe is registered trademarks of RephiLe Bioscience, Ltd.. TM and (R) may be omitted in this brochure.

RephiLe Bioscience, Ltd.

Toll Free: +1-855-RephiLe (+1-855-737-4453)

E-mail: info@rephile.com



Literature: RFP1832606