



Large Genie R

Benchtop High Output Water System



Produces RO water from tap water

Daily pure water production up to 1,900 L from tap water

Overview

The Large Genie R system produces RO pure water. Despite its small size, Large Genie R is capable of producing large volumes of purified water with reliable quality. It is an ideal solution for users who need large quantity high quality pure water per day but have limited lab space.

The systems are manufactured in ISO 9001:2015 and ISO 14001:2015 certified manufacturing sites. The systems are CE and RoHS certified.

**A small footprint
to maximize
your lab space**



Main Components



Control Console

- 8" touch screen, highly responsive with latex gloves for effortless system operation and control
- Comfortable viewing and operation with built in viewing angle and flexible placement by users
- Operable with gloves and wet hands
- Robust screen: easy to clean, resistant to scratches



Remote Dispenser

- Manual and volumetric dispensing, adjustable dispensing rate, and water quality monitoring
- Ergonomic dispenser allowing a handed operation and control
- Operable with gloves and wet hands
- Height adjustable and 360 degree rotatable on an anti-skid base

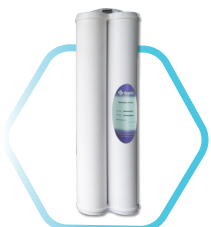

Cartridge

- Inbuilt filter, activated carbon and scale inhibitor to remove particles, chlorine and reduce hardness
- High pressure rated housings, proprietary sealing, and double o-ring designs ensuring operational confidence
- A worry-free installation with two verifications: labels and RFID recognition



Tank

- 30/60/100/350 liters separate tank with vent filter available for selection. Smooth inner surface to minimize biofilm formation and algal growth
- Provision for easy cleaning and fully drainable; Spray ball installation for efficient, effective and dependable cleaning
- Unique reinforcing-bar design to prevent deformation
- Consistent and accurate tank water level monitoring with a built-in continuous liquid level sensor
- Mercury-free germicidal UVC LED lamp (peak emission wavelength at 265 nm) equipped in tank sanitization module

Features



Easy-to-place

- Built-in pretreatment pack including prefiltration, chlorine removal and anti-scaling media; Generally no extra pretreatment needed
- Placement flexibility-wall-mounted, on the bench or on top of a distribution module (optional)
- Modular design. Plug and play connections for quick install



Easy-to-track

- RFID tracking of consumables, RO membranes and accessories to ensure optimal system performance and provide users with real-time operational intelligence
- Enhanced data management stores up to two years of historical information for service and review
- The ability to export and print data and log-in requirements are built into the system

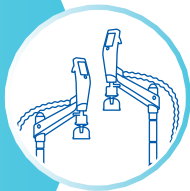

Easy-to-use

- "1+N mode" - one water system can drive N units of dispenser (Up to 10 now and can be upgraded further more).
- Stable RO permeability over a wide range of water temperatures



Easy-to-control

- Large Genie equips with multiple touch screens which are highly responsive, latex glove friendly, and perfect for wet labs.
- Intuitive display with comprehensive data views. No need to use additional paperwork or operating checklists.
- 9 display languages for selection
- RephiLink Mobile App provides real-time remote monitoring of the systems

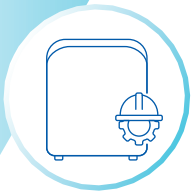

Easy-to-maintain

- No tools are needed for system maintenance and simple service.
- Automatic system shut-off upon detection of any water leakage

Main Applications

- Glassware cleaning
- Washing machine for glassware
- Water bath water
- Autoclave
- Feed water for laboratory animals

Flow Chart

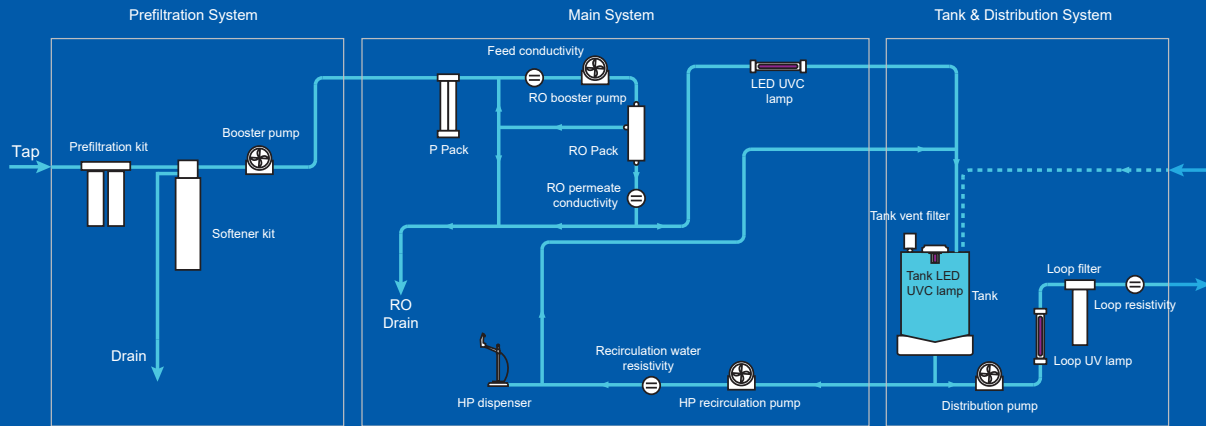

Specifications

Genie R	
Feed Water Requirements	
Feed water conductivity / TDS	< 2000 $\mu\text{S/cm}$ / < 1000 ppm
Operating temperature	5 - 35 $^{\circ}\text{C}$
Feed water pressure	0.2 - 0.6 MPa (2.0 - 6.0 bar)
Product Water Quality	
RO water	
Flow rate	40, 80 L/hr
Dispenser rate	Up to 2 L/min
Conductivity (@ 25 $^{\circ}\text{C}$)	Typically < 20 $\mu\text{S/cm}$ (feed water < 2000 $\mu\text{S/cm}$)
RO rejection	97 to 98% ionic rejection (new RO cartridge) > 99% organic rejection > 99% particulates & bacteria rejection
Dimensions & Weight	
Main system:	
Width x Depth x Height	57 cm x 46 cm x 71 cm
Weight (Net)	< 36 kg
Dispenser:	
Width x Depth x Height	21 cm x 29 cm x 61 cm
Electrical connections and specifications	
Input voltage	100 - 240 VAC
Frequency	50/60 Hz
Power	< 250 W

Ordering Info

Description	Cat. No.
Genie R 40 Water System set	RG0R04000K
Genie R 80 Water System set	RG0R08000K

* Please contact us directly for information on ordering parts and accessories.

The Large Genie R is manufactured in RephiLe's ISO 9001:2015 and ISO 14001:2015 certified facility, complies with IEC international standards, and has received CE and RoHS directive certifications from the European Union.

RephiLe Bioscience, Ltd.

Toll Free: +1-855-RephiLe (+1-855-737-4453)

E-mail: info@rephile.com

All rights reserved © 2026 RephiLe Bioscience, Ltd.

RephiLe and Genie are registered trademarks of RephiLe Bioscience, Ltd.

All other trademarks mentioned are the property of their respective owners.

TM and © may be omitted in this brochure.

