

NuZar

Water Purification Systems

Compact
and powerful.



NuZar U
NuZar Q
NuZar E
NuZar R
NuZar H
NuZar C / NuZar C-DI

The system is manufactured in our production facility registered by ISO 9001:2015 & ISO 14001:2015. It is CE/RoHS certified.

About NuZar Laboratory Water Systems

The NuZar systems introduce a unique series to the RephiLe water purification portfolio. They deliver powerful performance in a compact size, meeting your pure water requirements while also saving valuable space for your research.

The NuZar system is ready to install right out of the packaging, and all setups are straightforward. The simplified and user-centered designs of the NuZar series make them easy to use, even for inexperienced users. This contributes to streamlining workflows, ultimately enhancing the quality and productivity of the laboratory.

In general, NuZar lite systems can provide users with consistent water quality, effortless operation, user-friendly monitoring, and a favorable cost of ownership.

The series includes 7 models:



Feed Water	Product Water
HP* Tap	UP** HP*
● NuZar U	● (RO)
● NuZar E	● (EDI)
● NuZar H	● (DI)
● NuZar R	● (RO)
● ● ● NuZar Q	●
● NuZar C	● (CLRW)
● ● ● NuZar C-DI	● (CLRW)

*HP: Purified water **UP: Ultrapure Water

Key Features

Reliable, Stable, Traceable and Predictable

Simple installation and maintenance

- ◇ RFID tracking of consumables (RO Pack included) for enhanced management
- ◇ Easy to remove consumable access cover.
- ◇ Automatic RO membrane cleaning cycles (Cl₂ and pH cleaning)

Low running cost

- ◇ Self-maintenance functions for maximum RO membrane effectiveness and lifetime
- ◇ RFID record of cartridge history for predictable consumable replacements
- ◇ Highly-efficient cartridges

Reliable water quality and stable system performance

- ◇ Stable RO permeability over a wide range of temperatures
- ◇ Diversion to drain if quality of RO permeate falls below a pre-set set-point
- ◇ Automatic hourly recirculation of ultrapure water
- ◇ Mercury-free germicidal UV lamp preinstalled in tank sanitation module

Data traceability

- ◇ Automatic data backup for up to 2 years
- ◇ Easy data transfer through multiple interfaces, such as LAN, USB, etc.

Compact and small footprint

- ◇ An in-built single pretreatment P Pack
- ◇ Placement flexibility - on the bench or on a wall
- ◇ Two dispenser heights
- ◇ All-in-one design. Space-Saver



RFID technology



Data traceability



Low running cost



Small foot-print



Environmentally friendly

Components & Parts



Cartridge

- Optimized flow design to improve water quality stability & efficiency of polishing resins
- High pressure rated housings, proprietary sealing, and double O-ring design ensures operational confidence
- Cartridge color, label, and RFID recognition prevent incorrect installation



Ergonomic dispenser with 2.4" color touch screen

- One dispenser for one system (two for NuZar U)
- Intuitive display - water quality with temperature compensation, volumetric dispensing and flow rate
- System alerts are displayed on the touch screen
- Effortless adjustment - dispensing rate (up to 2 L/min), manual and volumetric dispensing
- Choice of final filters: RephiBio and 0.2 µm final filter



Two dispenser heights for the ultimate in flexibility



Storage Tank

- A 10 L integrated HDPE tank (not for NuZar Q / NuZar C-DI) equipped with sanitization module, mercury-free germicidal UV lamp preinstalled.
- Tank recirculation function specifically for NuZar H to guarantee water quality in the tank







Extendable to 30/60/100/350 L (with mercury-free tank sanitization module) if needed



Select a right NuZar system for your applications

Easy Selections Peace of Mind!

NuZar System	Water type	Main Applications
	Ultrapure water	<ul style="list-style-type: none"> HPLC mobile phase preparation Preparation of reagent blank solutions Sample diluent for GC, HPLC, ICP-MS or other analytical techniques Preparation of buffers and culture media for cell culture Preparation of molecular biology reagents, etc.
	EDI / DI water	<ul style="list-style-type: none"> Preparation of chemical and bio-reagents Preparation of culture media / buffer Water supply for clinical analyzers Medical device and equipment rinsing For serum and blood fractionation Water supply for ultrapure water systems
	Pure water	<ul style="list-style-type: none"> Dilution of clinical reagents, samples and detergents Automatic medical device and equipment rinsing Reaction cuvettes cleaning Feeding washing stations for probe tips and stirrer paddles Temperature controlled Incubator baths An interface between syringe and sample
	RO water	<ul style="list-style-type: none"> Washing machine for glassware cleaning Feed water for laboratory animals Feed water for humidifiers, autoclaves, etc. Water supply for ultrapure water systems Hydroponics

Flow Schematics

Rephile NuZar systems incorporate advanced technologies and optimized flow paths to ensure exceptional water quality for customers' applications.

Comprehensive process control management with continuous water purity monitoring after every purification step. This allows consistent and reliable operation which ensures the product meets the NuZar specifications.

NuZar Q Pure water to ultrapure water

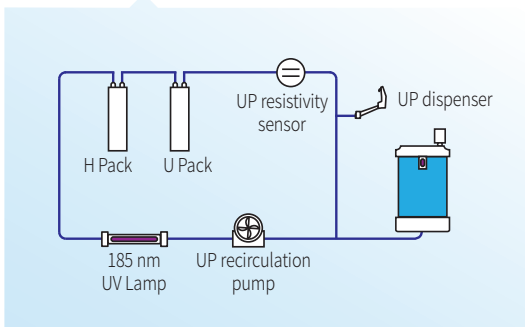

NuZar U Tap water to ultrapure & RO water (24 L/h)

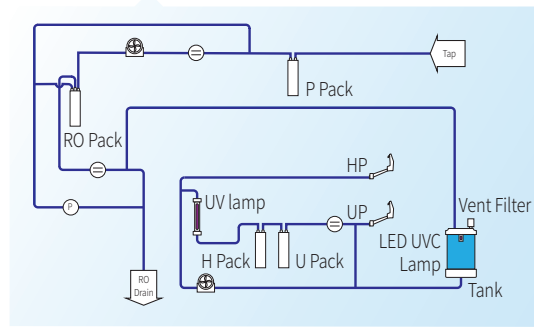

NuZar E Tap water to EDI water (10 L/h) with an EDI module

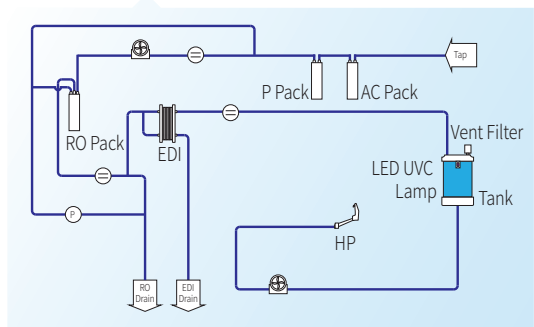

NuZar H Tap water to DI water (24 L/h) with tank recirculation function

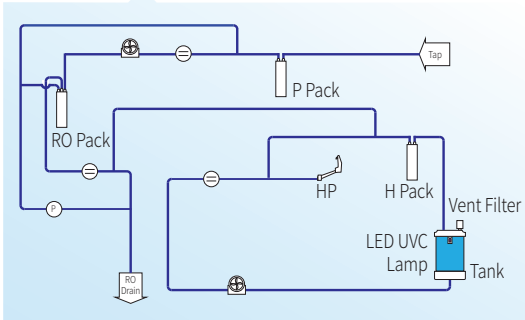

NuZar R Tap water to RO water (24 L/h) with automatic RO flush and rinsing

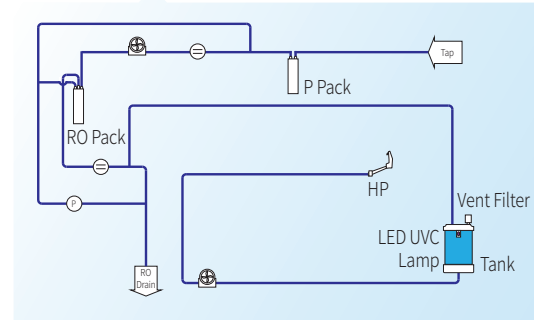

NuZar C Tap water to Pure water (CLRW) (24 L/h)

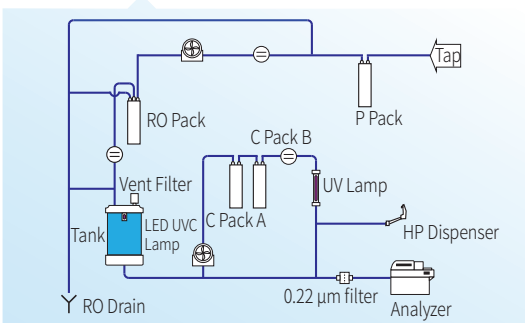

NuZar C_{DI} Pure water to Pure water (CLRW)

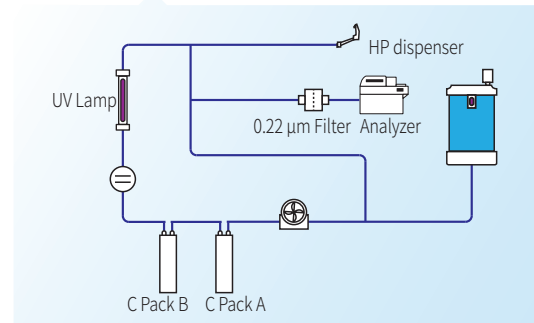

- Dispenser
- Conductivity / Resistivity Sensor
- Booster / Recirculation Pump
- Pressure Sensor

Water Quality Compliance

Quality of ultrapure water meets or exceeds ASTM, CLSI, CAP and ISO Type I water standards. Quality of high pure water meets or exceeds ASTM, CLSI, CAP and ISO Type II water standards and also complies with the Purified Water requirements from the European and U.S. Pharmacopoeia. NuZar C / NuZar C-DI: The product water quality fulfills the critical needs within the clinical laboratory, in compliance with CLSI Clinical Laboratory Reagent Water (CLRW) quantitative specifications.

Specifications

General Specifications		NuZar Q	NuZar C-DI	NuZar U	NuZar R	NuZar E	NuZar H	NuZar C
Operating voltage		24 VDC						
Input voltage		100 - 240 VAC						
Main system power		< 190 W						
Feed Water Requirements								
Feed water conductivity / TDS		EDI, RO, Distilled, Deionized water			Tap water < 2000 μ S/cm / < 1000 ppm			
Operating temperature		5 – 35 °C						
Feed water pressure		0 - 1 bar (0 - 15 psi)*			1 - 6 bar (15 - 90 psi)			
Product Water Type		Ultrapure ●	Pure ●	Ultrapure & RO ● ●	RO ●	EDI ●	DI ●	Pure ●
Dimensions W x D x H	w/ integrated tank	NuZar U: 491 x 422 x 624 mm (19.3 x 16.6 x 24.5 in) NuZar E / H / R / C: 414 x 422 x 624 mm (16.3 x 16.6 x 24.5 in) NuZar Q / C-DI: 414 x 310 x 624 mm (16.3 x 12.2 x 24.5 in)						
Weight (Approximate)	net	18 kg	18 kg	21 kg	19 kg	21 kg	20 kg	20 kg
	gross	27 kg	27 kg	30 kg	28 kg	30 kg	29 kg	29 kg

*It's recommended to use a pressure regulator if feed water pressure is above 15 psi (1 bar)

Product water Specifications	NuZar U / Q ● Ultrapure water	NuZar E ● EDI water	NuZar H ● DI water	NuZar C ● Pure water	NuZar C-DI ● Pure water	NuZar R ● RO water
Production rate	-	10 L/hr	24 L/hr	24 L/hr	-	24 L/hr
Dispenser rate	Up to 2 L/min					
Conductivity (@25°C)	-	-	-	-	-	Typically < 20 μ S/cm
RO rejection (Not for Q or C-DI)	97 to 98% ionic rejection (new RO cartridge) > 99% organic rejection > 99% particulates & bacteria rejection					
Resistivity (@25°C)	18.2 M Ω · cm	> 5 M Ω · cm (typically 10 - 16 M Ω · cm)	> 1 M Ω · cm Product water quality stored in tank	> 10 M Ω · cm (typically > 16 M Ω · cm)		-
TOC	< 5 ppb*	< 30 ppb**	-	< 30 ppb		-
Particles	No Particles with size > 0.22 μ m***	-	-	No Particles with size > 0.22 μ m***		-
Microorganisms	< 0.001 cfu/ml***	-	-	< 1 CFU/ml		-
Pyrogens (endotoxins)	< 0.001 Eu/ml****	-	-	-	-	-
RNase	< 0.5 pg/ml****	-	-	-	-	-
DNase	< 10 pg/ml****	-	-	-	-	-
Silica	-	-	-	< 5 μ g/L		-

*When TOC Level of feed water is < 50 ppb.

**Product water quality may vary due to local feed water conditions.

***with a 0.2 μ m final filter

****with a RephiBio filter and ISO Type I water standards

Ordering Info

Description	Cat. No.
NuZar water system set, U24	RN0U020T1K
NuZar water system set, E10	RN0E010T1K
NuZar water system set, R24	RN0R020T1K
NuZar water system set, H24	RN0H020T1K

Description	Cat. No.
NuZar water system set, Q	RN0Q00000K
NuZar water system set, C24	RN0C020T1K
NuZar water system set, C-DI	RN0CD0000K

Installation Information

Plug-N-Play with only 3 steps

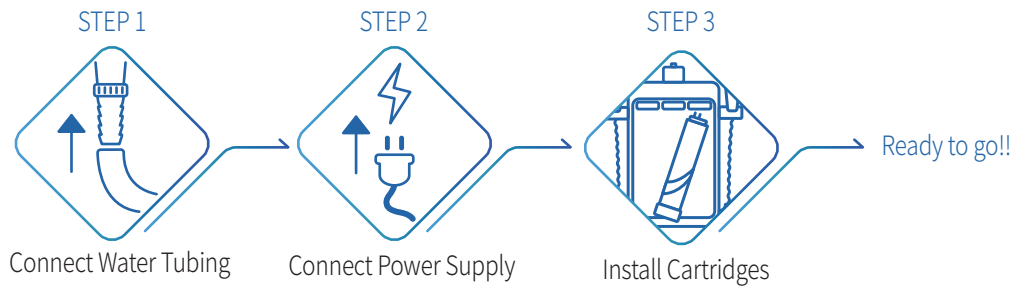

Installation instructions

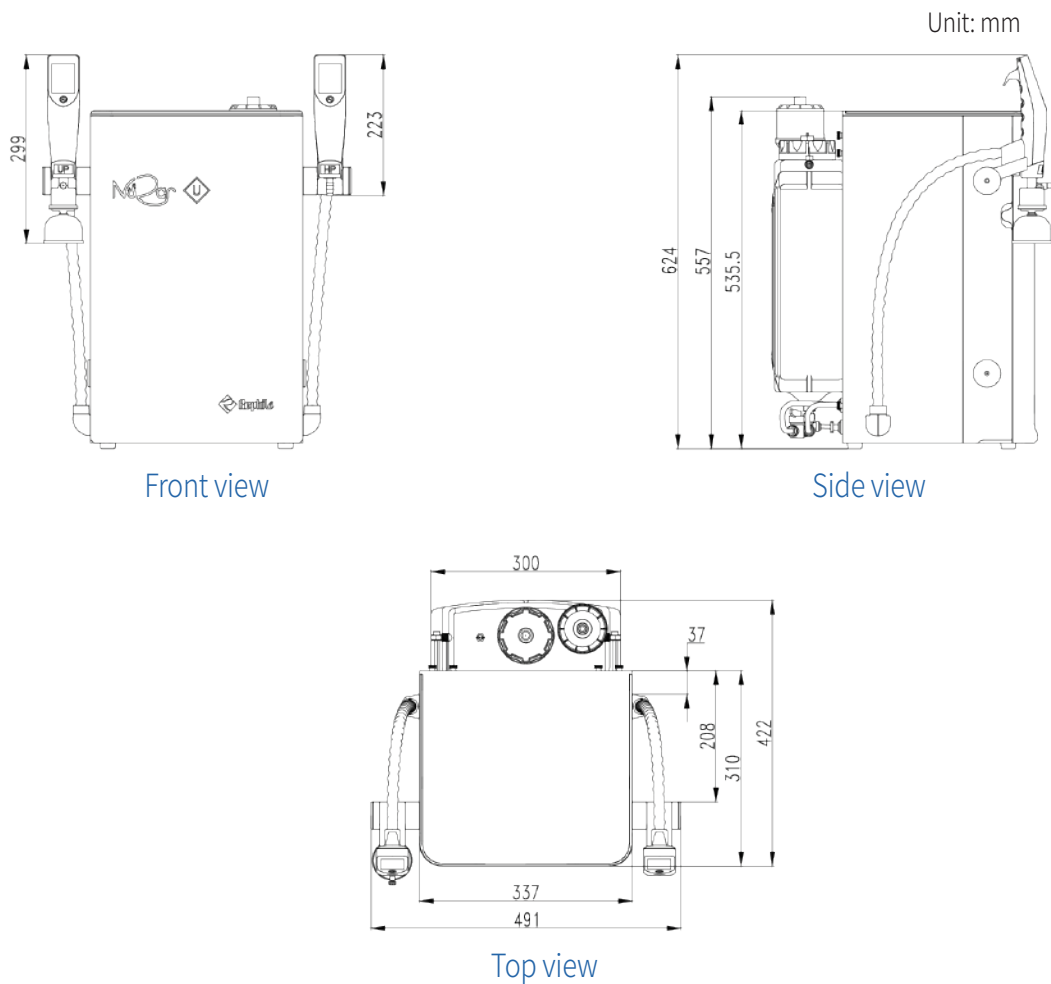

All rights reserved © 2024 RephiLe Bioscience, Ltd.
RephiLe and NuZar are registered trademarks of RephiLe Bioscience, Ltd.
All other trademarks mentioned are the property of their respective owners.
™ and ® may be omitted in this brochure.
RephiLe Bioscience, Ltd.

Toll Free: +1-855-RephiLe (+1-855-737-4453)
E-mail: info@rephile.com

Literature: RFP1442403

