

Genie PURIST



Ultrapure water for critical laboratory applications

Genie PURIST ultrapure water system produces Type I ultrapure water from RO, distilled or deionized water. Quality of ultrapure water meet or exceeds ASTM, CLSI, CAP, and ISO Type I water standards.

The system is manufactured in ISO 9001:2015 and ISO 14001:2015 certified manufacturing sites. The system is CE and RoHS certified.

Features

- Wireless communication amongst components providing unlimited possibilities
- RFID tracking of consumables and accessories to ensure optimal system performance
- On-line TOC based on complete oxidation methodology
- A full range of cartridges for various applications including ultra-low TOC, low Mg, low boron, ICP and DI type
- Eliminating bacteria and reducing TOC to trace level by a dual wavelength UV lamp
- Placement flexibility- on the bench, under the sink or wall-mounted to save valuable space within a lab
- A universal water level sensor to prevent the system from pumping air
- An optional automatic system shut-off upon detection of any water leakage
- Choices of final filters to remove specific contaminants
- 9 display languages for selection

- ◆ Advanced wireless communication technologies offer more freedom than ever for a remote dispenser. Its distance from the system is no longer limited by the length of cables or wires, and can be discretely set up into a hood or a clean room.
- ◆ "1+N mode" - one water system can drive N units of dispenser (Up to 10 now and can be upgraded further more).
- ◆ Genie equips with multiple touch screens which are highly responsive, water-proof, latex glove friendly, and perfect for wet labs.
- ◆ Monitoring of consumables and accessories, through RFID technology, provides users with real-time operational intelligence.
- ◆ The ability to export and print data and log-in requirements are built into all of our Genie systems.
- ◆ Feed water conductivity monitoring ensures an optimal running conditions of the system.
- ◆ A RephiBio filter can be embraced to produce pyrogen, nuclease and bacteria free water for critical applications.
- ◆ No tools are needed for system maintenance and simple service.



Flow Chart

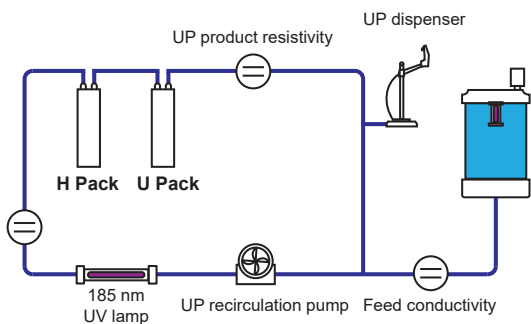

Main Applications

With Ultrapure Water

- HPLC mobile phase preparation
- Preparation of reagent blank solutions
- As sample diluent for GC, HPLC, UPLC, ICP-MS, AA and other analytical techniques
- Preparation of buffers and culture media for mammalian cell culture
- Preparation of molecular biology reagents, etc.

Main Components



Command and control center

- 8-inch touch screen with highly intuitive navigation program allowing total control and easy operation of the system
- Comfortable viewing and operation with built in viewing angle and flexible placement by users
- Operable with gloves and wet hands
- Robust screen: easy to clean, resistant to scratches



Smart and flexible remote dispensers

- Manual and volumetric dispensing, adjustable dispensing rate, and water quality monitoring
- Ergonomic dispenser allowing one handed operation and control
- Operable with gloves and wet hands
- Height adjustable and 360 degree rotatable on an anti-skid base



Powerful key of purification

- Improved stability of water quality & efficiency of polishing resins due to optimized flow design
- High pressure rated housings, proprietary sealing, and double o-ring designs ensuring operational confidence
- A worry-free installation with three verifications: color, labels, and RFID recognition

Ordering Info

Description	Cat. No.
Genie PURIST System	RGOS00000
Genie PURIST System, with TOC	RGOS000T0

Specifications

Product Water Quality

	Genie PURIST
Dispenser rate	Up to 2 L/min
Resistivity (@25 °C)	18.2 MΩ·cm
TOC*	< 2 ppb
Particles (> 0.2 µm)**	No particles with size > 0.22 µm
Microorganisms**	< 0.001 cfu/ml
Pyrogens (endotoxins)***	< 0.001 Eu/ml
RNase***	< 0.5 pg/ml
DNase***	< 10 pg/ml

* In the appropriate operating conditions, otherwise typically ≤5 ppb.

** with a 0.2 µm final filter

*** with a RephiBio filter

Main System Specifications

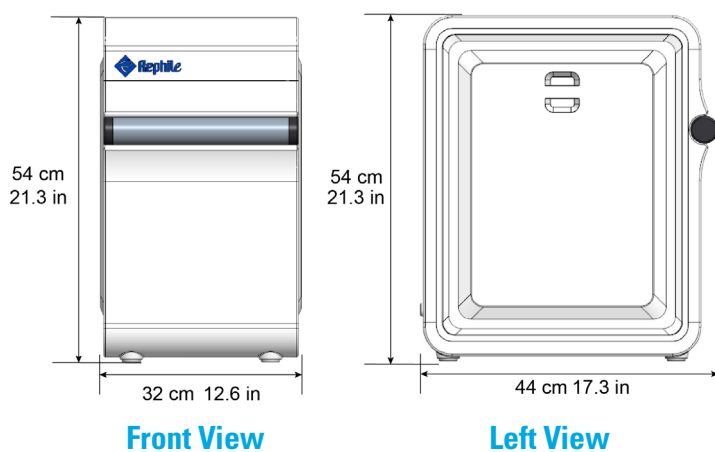

Feed Water & Environment Requirements

	Genie PURIST
Feed water	Pure water
Conductivity	< 100 µS/cm@25 °C
Temperature	5 - 35 °C (41 - 95 F)
Pressure	0 - 0.1 MPa (0 - 1.0 bar)
TOC	< 50 ppb
Environment	
Operational temperature	5 - 45 °C (41 - 113 F)
Humidity	20 - 80%

Dispenser Specifications

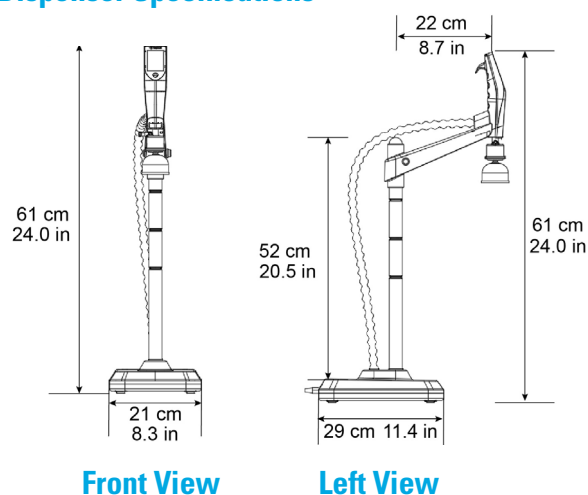

	Genie PURIST
System weight	< 17 kg
Control console weight	0.75 kg
Input voltage / frequency	100 - 240 VAC / 50 - 60 Hz
Operating voltage	24 VDC
Power	< 190 W
Data connection	CAN / USB / SD / WIFI

	Dispenser
Weight	5 kg
Dispenser tubing length	1 m (3.3 ft)
Distance from main system to dispenser (wire)	3 m (9.8 ft)
Distance from main system to dispenser (wireless)	10 m (32.8 ft)
Operating voltage	24 VDC

All rights reserved © 2024 RephiLe Bioscience, Ltd.
RephiLe and Genie are registered trademarks of RephiLe Bioscience, Ltd.. TM and (R) may be omitted in this brochure.

RephiLe Bioscience, Ltd.

Toll Free: +1-855-RephiLe (+1-855-737-4453)

E-mail: info@rephile.com



Literature: RFP1372403