

Genie A



Generates ultrapure water and RO water on demand from the system

Genie A is a plug-and-play lab water system with small foot print. It is an ideal choice for users who need up to 20 liters of ultrapure water or RO water per day. Quality of ultrapure product water meets or exceeds ASTM, CLSI, CAP, and ISO Type I water standards.

The system is manufactured in ISO 9001 : 2015 and ISO 14001:2015 certified manufacturing sites. The system is CE and RoHS certified.

Features

- Wireless communication amongst components providing unlimited possibilities
- RFID tracking of consumables and RO membranes to ensure optimal system performance
- On-line TOC measurement based on complete oxidation methodology
- No storage tank needed: eliminating potential contamination from the storage tank
- Compact design: no additional pre-treatment filters required; remote dispenser on the system
- Consistent and stable RO permeability over a wide range of temperature
- RO removes > 97% of ions and large molecules; > 99% of microorganisms, particles and bacteria
- A full range of cartridges for various applications including ultra-low TOC, low Mg, low boron, ICP and DI type
- Placement flexibility- on the bench, under the sink or wall-mounted to save valuable space within a lab
- Automatic system shut-off upon detection of any water leakage
- 9 display languages for selection

- ◆ Advanced wireless communication technologies offer more freedom than ever for a remote dispenser. Its distance from the system is no longer limited by the length of cables or wires, and can be discretely set up into a hood or a clean room.
- ◆ "1+N mode" - one water system can drive N units of dispenser (Up to 10 now and can be upgraded further more).
- ◆ Genie equips with multiple touch screens which are highly responsive, water-proof, latex glove friendly, and perfect for wet labs.
- ◆ Monitoring of consumables and accessories, through RFID technology, provides users with real-time operational intelligence.
- ◆ The ability to export and print data and log-in requirements are built into all of our Genie systems.
- ◆ Feed water conductivity monitoring ensures optimal running conditions of the system.
- ◆ A RephiBio filter can be embraced to produce pyrogen, nuclease and bacteria free water for critical applications.
- ◆ No tools are needed for system maintenance and simple service.

A

Flow Chart

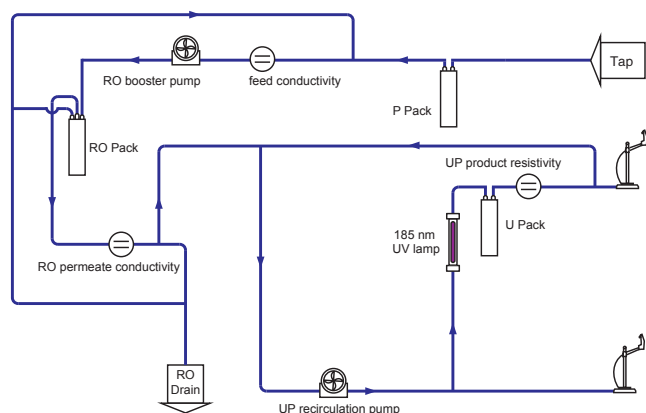

Main Applications

With Ultrapure Water

- HPLC mobile phase preparation
- Preparation of reagent blank solutions
- As sample diluent for GC, HPLC, UPLC, ICP-MS, AA and other analytical techniques
- Preparation of buffers and culture media for mammalian cell culture
- Preparation of molecular biology reagents, etc.

With RO Water

- Glassware cleaning
- Washing machine for glassware
- Water bath water
- Autoclave
- Feed water for laboratory animals

Main Components



Control Console



Remote Dispenser



Cartridges

Command and control center

- 8-inch touch screen with highly intuitive navigation program allowing total control and easy operation of the system
- Comfortable viewing and operation with built in viewing angle and flexible placement by users
- Operable with gloves and wet hands
- Robust screen: easy to clean, resistant to scratches

Smart and flexible remote dispensers

- Manual and volumetric dispensing, adjustable dispensing rate, and water quality monitoring
- Ergonomic dispenser allowing one handed operation and control
- Operable with gloves and wet hands

Powerful key of purification

- Improved stability of water quality & efficiency of polishing resins due to optimized flow design
- High pressure rated housings, proprietary sealing, and double o-ring designs ensuring operational confidence
- A worry-free installation with three verifications: color, labels, and RFID recognition

Ordering Info

Description	Cat. No.
Genie A System	RG0A04000
Genie A System, with TOC	RG0A040T0

Specifications

Product Water Quality

Genie A	
RO water	
Dispenser rate	Typically 0.5 L/min
RO rejection	97 to 98% ionic rejection (new RO cartridge), > 99% organic rejection, > 99% particulates & bacteria rejection
Conductivity (@ 25 °C)	Typically < 20 µS/cm (feed water < 2000 µS/cm)
Ultrapure water	
Dispenser rate	Typically 0.5 L/min
Resistivity (@25 °C)	18.2 MΩ·cm
TOC*	< 2 ppb
Particles (> 0.2 µm)**	No particles with size > 0.22 µm
Microorganisms**	< 0.001 cfu/ml
Pyrogens (endotoxins)***	< 0.001 Eu/ml
RNase***	< 0.5 pg/ml
DNase***	< 10 pg/ml

* In the appropriate operating conditions, otherwise typically ≤ 5 ppb.

** with a 0.2 µm final filter

*** with a RephiBio filter

Feed Water & Environment Requirements

Genie A	
Feed water	Tap water
Conductivity	< 2000 µS/cm@25 °C (TDS < 1000 ppm)
Temperature	5 - 35 °C (41 - 95 F)
Pressure	0.1 - 0.6 MPa (1.0 - 6.0 bar)
pH	4 - 10
Hardness (as CaCO ₃)	< 180 mg/L (180 ppm)*
TOC	< 2000 ppb
Silica	< 30 mg/L (< 30 ppm)
Dissolved CO ₂	< 30 mg/L (< 30 ppm)
Langlier saturation index (LSI)	< 0.3
SDI	≤ 3
Free chlorine	< 1.5 mg/L (< 1.5 ppm)
Environment	
Operational temperature	5 - 45 °C (41 - 113 F)
Humidity	20 - 80%

* > 180 ppm: softener recommended

Main System Specifications

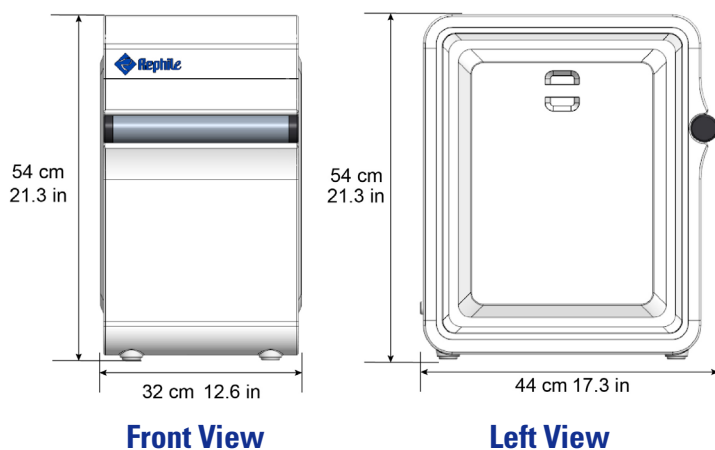

Dispenser Specifications

Dispenser	
Dispenser tubing length	1 m (3.3 ft)
Operating voltage	24 VDC

Genie A	
System weight	< 20 kg
Control console weight	0.75 kg
Input voltage / frequency	100 - 240 VAC / 50 - 60 Hz
Operating voltage	24 VDC
Power	< 190 W
Data connection	CAN / USB / SD / WIFI

All rights reserved © 2024 RephiLe Bioscience, Ltd.
RephiLe and Genie are registered trademarks of RephiLe Bioscience, Ltd. TM and (R) may be omitted in this brochure.

RephiLe Bioscience, Ltd.

Toll Free: +1-855-RephiLe (+1-855-737-4453)

E-mail: info@rephile.com



Literature: RFP1402403