

Genie R

12 / 24 / 32



Produces reverse osmosis (RO) laboratory-grade water from tap water directly

Genie R applies high recovery reverse osmosis (RO) technology to produce pure water for general laboratory needs with easy maintenance and low running costs.

The system is manufactured in ISO 9001:2015 and ISO 14001:2015 certified manufacturing sites. The system is CE and RoHS certified.

Features

- Wireless communication amongst components providing unlimited possibilities
- RFID tracking of consumables and RO membranes to ensure optimal system performance
- Stable RO permeability over a wide range of water temperatures
- RO removes > 97% of ions and large molecules; > 99% of microorganisms, particles and bacteria
- Consistent and accurate tank water level monitoring with a built-in continuous liquid level sensor in the storage tank
- Mercury-free germicidal UV LED (265 nm) lamp equipped in tank sanitization module
- Tank recirculation model guarantees water quality in the tank
- Automatic system shut-off upon detection of any water leakage
- Placement flexibility- on the bench, under the sink or wall-mounted to save valuable space within a lab
- 9 display languages for selection

- ◆ Advanced wireless communication technologies offer more freedom than ever for a remote dispenser. Its distance from the system is no longer limited by the length of cables and wires, and can be discretely set up into a hood or a clean room.
- ◆ "1+N mode" - one water system can drive N units of dispenser (Up to 10 now and can be upgraded further more).
- ◆ Genie equips with multiple touch screens which are highly responsive, water-proof, latex glove friendly, and perfect for wet labs.
- ◆ Monitoring of consumables and accessories, through RFID technology, provides users with real-time operational intelligence.
- ◆ The ability to export and print data and log-in requirements are built into all of our Genie systems.
- ◆ Feed water conductivity monitoring ensures an optimal running conditions of the system.
- ◆ No tools are needed for benchtop installation.

R

Flow Chart

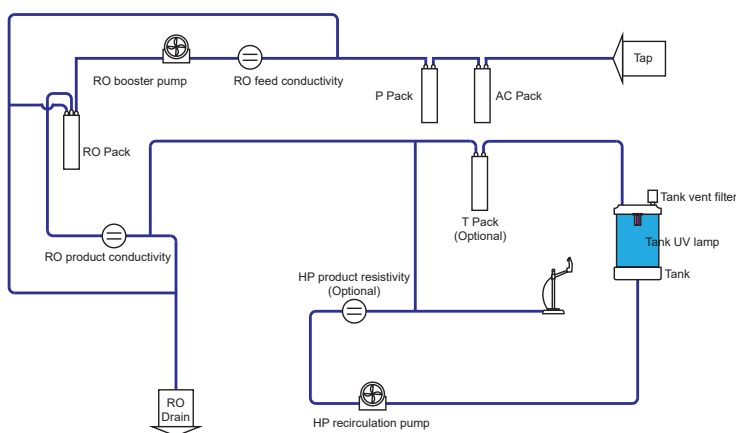

Main Applications

With RO Water

- Glassware cleaning
- Washing machine for glassware
- Water bath water
- Autoclave
- Feed water for laboratory animals

Main Components



Control Console



Remote Dispenser



Cartridges



Tank

Command and control center

- 8-inch touch screen with highly intuitive navigation program allowing total control and easy operation of the system
- Comfortable viewing and operation with built in viewing angle and flexible placement by users
- Operable with gloves and wet hands
- Robust screen: easy to clean, resistant to scratches

Smart and flexible remote dispensers

- Manual and volumetric dispensing, adjustable dispensing rate, and water quality monitoring
- Ergonomic dispenser allowing one handed operation and control
- Operable with gloves and wet hands
- Height adjustable and 360 degree rotatable on an anti-skid base

Powerful key of purification

- Improved stability of water quality & efficiency of polishing resins due to optimized flow design
- High pressure rated housings, proprietary sealing, and double o-ring designs ensuring operational confidence
- A worry-free installation with three verifications: color, labels, and RFID recognition

Reservoir

Specifications

	30 L Tank	60 L Tank	100 L Tank
Materials	HDPE	HDPE	HDPE
Width x depth x height	42 x 34 x 61 cm 16.5 x 13.4 x 24.0 in	42 x 34 x 85 cm 16.5 x 13.4 x 33.5 in	55 x 27 x 138 cm 21.7 x 10.6 x 54.3 in
Dry weight	7 kg	11 kg	35 kg
Operating weight	37 kg	71kg	135 kg

Ordering Info

Description	Cat. No.
Genie R 12 System	RGOR01000
Genie R 24 System	RGOR02000
Genie R 32 System	RGOR03000
Genie R 12 System, with tank recirculation	RGOR0100R
Genie R 24 System, with tank recirculation	RGOR0200R
Genie R 32 System, with tank recirculation	RGOR0300R

Specifications

Product Water Quality

Genie R	
RO water	
Flow rate	12, 24, 32 L/hr
Dispenser rate	Up to 2 L/min
RO rejection	97 to 98% ionic rejection (new RO cartridge), > 99% organic rejection, > 99% particulates & bacteria rejection
Conductivity (@ 25 °C)	Typically < 20 µS/cm (feed water < 2000 µS/cm)
Water stored in tank (for tank recirculation models)	
Resistivity (@ 25 °C)	> 1 MΩ·cm (default), adjustable

Feed Water & Environment Requirements

Genie R	
Feed water	Tap water
Conductivity	< 2000 µS/cm@25 °C (TDS < 1000 ppm)
Temperature	5 - 35 °C (41 - 95 F)
Pressure	0.1 - 0.6 MPa (1.0 - 6.0 bar)
pH	4 - 10
Hardness (as CaCO ₃)	< 180 mg/L (180 ppm)*
TOC	< 2000 ppb
Silica	< 30 mg/L (< 30 ppm)
Dissolved CO ₂	< 30 mg/L (< 30 ppm)
Langlier saturation index (LSI)	< 0.3
SDI	≤ 3
Free chlorine	< 1.5 mg/L (< 1.5 ppm)
Environment	
Operational temperature	5 - 45 °C (41 - 113 F)
Humidity	20 - 80%

* > 180 ppm: softener recommended

Main System Specifications

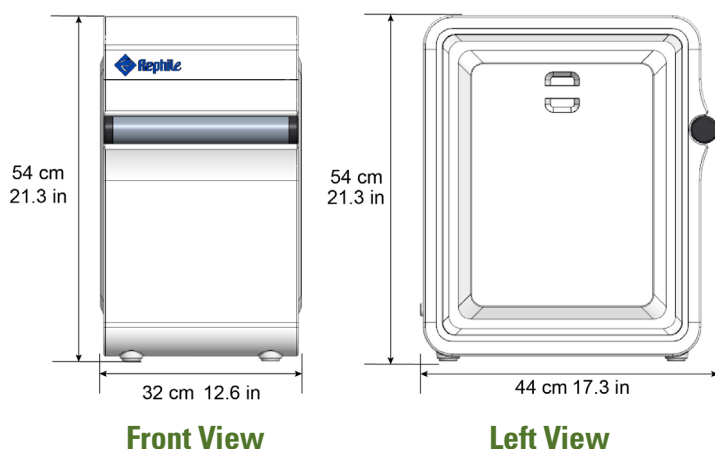

Dispenser Specifications

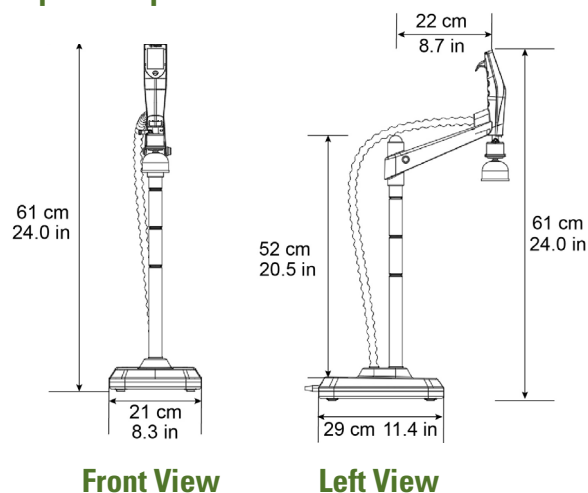

Genie R	
System weight	< 20 kg
Control console weight	0.75 kg
Input voltage / frequency	100 - 240 VAC / 50 - 60 Hz
Operating voltage	24 VDC
Power	< 190 W
Data connection	CAN / USB / SD / WIFI

Dispenser	
Weight	5 kg
Dispenser tubing length	1 m (3.3 ft)
Distance from main system to dispenser (wire)	3 m (9.8 ft)
Distance from main system to dispenser (wireless)	10 m (32.8 ft)
Operating voltage	24 VDC

All rights reserved © 2023 RephiLe Bioscience, Ltd.
RephiLe and Genie are registered trademarks of RephiLe Bioscience, Ltd. TM and (R) may be omitted in this brochure.

RephiLe Bioscience, Ltd.

Toll Free: +1-855-RephiLe (+1-855-737-4453)

E-mail: info@rephile.com



Literature: RFP1392308