

Storage Tanks for Pure Water

Protect the quality of purified water based on the best proven technology & designs

A storage tank is an essential component in a water purification system and maintaining the purity of stored water is of great importance.

Rephile offers a series of high quality tanks (30 L, 60 L, 100L, 350 L) together with choices of accessories to provide reliable protection of purified water, which forms a solid base for all downstream applications of pure water.



Good Production Technique • Best Raw Material • Thoughtful Designs

Product Features

- High purity inert HDPE material. HDPE has little branching, making it stronger intermolecular forces and tensile strength, results in
 - Low extractable
 - Opacity
 - Smooth surface characteristics
 - Durability
- Opaque construction and smooth inner surface to minimize biofilm formation and algal growth
- No dead volume thanks to cylindrical shape and conical bottom design. Easy in emptying and cleaning
- Threaded lid for airtight closure, preventing air from entering inside the tank
- A vent filter to guard the water tank against particles and microbes from atmosphere. It contains
 - Soda lime in granular form, which removes carbon dioxide CO₂ from air and is known as “CO₂ scavenger”
 - Granular activated carbon or GAC, which removes organic matter from the air
 - 0.22 hydrophobic membrane, which removes air-borne bacteria
- Rectangular shape for spacing-saving solutions and easier ways to make a lab tidy and organized. Unique reinforcing-bar design to prevent deformation for 100 L & 350 L tanks
- Provision for easy cleaning and fully drainable



Conical Bottom Design

Storage Tanks for Pure Water

Storage tanks for Genie, NuZar and Super-Genie water systems

- Continuous liquid level sensor for exact measurement of water level at any point
- Overflow protection sensors managed by control console. Convenient and worry-free

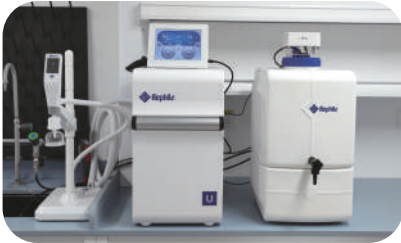

Optional Accessories

- Compact design of UV sanitization module to effectively reduce bacterial proliferation inside the tank
- Distribution units with pump base in a stainless steel frame to distribute water to points of use
- Spray ball installation for efficient, effective and dependable cleaning



Mercury-free germicidal UVC LED lamp (265 nm) in tank sanitization module

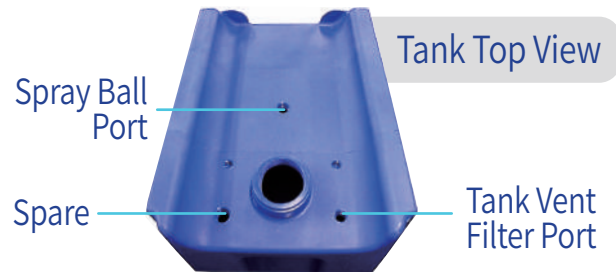

Storage tanks for Direct-Pure water systems

A storage tank for a Direct-Pure system uses a float sensor with programmed high/medium/low level cut-offs to guarantee the proper operation of the system, preventing overflow, low level or costly damage to a pump.



Stainless Steel Tank Level Sensor for 100 & 350 L reservoirs



Optional Accessories



Distribution Controller



Sanitization Module & 254 nm UV lamp

Specifications

30 / 60 / 100 / 350 L Storage Tanks

| Size (cm/inch) Volume (liter) | W | D | H1 | H2 |
|----------------------------------|-----------|-----------|------------|------------|
| 30 | 34 / 13.4 | 45 / 17.7 | 66 / 25.9 | 61 / 24.0 |
| 60 | 34 / 13.4 | 45 / 17.7 | 90 / 35.4 | 85 / 33.5 |
| 100 | 56 / 22.0 | 27 / 10.6 | 148 / 58.3 | 137 / 53.9 |
| 350 | 56 / 22.0 | 72 / 28.3 | 148 / 58.3 | 137 / 53.9 |

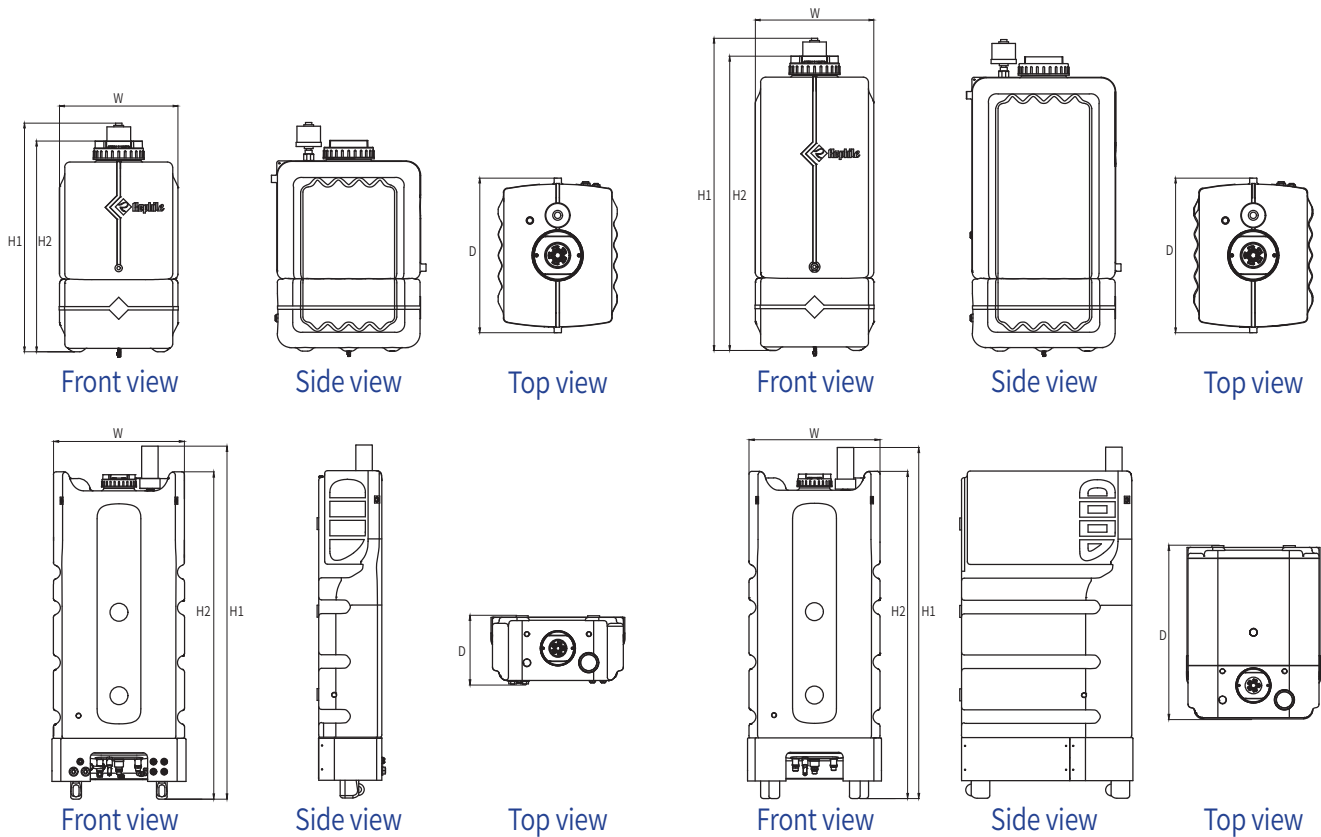

Weight of Empty Storage Tanks with Packing

| Weight (kg/lb) Volume (liter) | For Genie & NuZar | For Super-Genie | For Direct-Pure |
|----------------------------------|-------------------|-----------------|-----------------|
| 30 | 8.9 / 19.6 | 8.9 / 19.6 | 8.9 / 19.6 |
| 60 | 13.3 / 29.3 | 13.3 / 29.3 | 13.3 / 29.3 |
| 100 | 30 / 66.1 | 30 / 66.1 | 30 / 66.1 |
| 350 | 75 / 165.3 | 75 / 165.3 | 75 / 165.3 |
| 350 (with pump) | 120 / 264.6 | 120 / 264.6 | - |

Storage Tanks for Pure Water

Tank Vent Filters



Applicable to 30 L / 60 L storage tanks (Genie, NuZar & Direct-Pure systems)
100 L (Genie & NuZar systems)

Applicable to 100 L & 350 L storage tanks (Direct-Pure & Super-Genie systems)



Ordering Info

| | Description | Catalogue No. |
|--------------------|---|---------------|
| Genie Series | 30 L Tank with Tank UV for Genie & NuZar | RATK030GE |
| | 60 L Tank with Tank UV for Genie & NuZar | RATK060GE |
| NuZar Series | 100 L Tank with Tank UV for Genie & NuZar | RATK100GE |
| | 350 L Tank with Tank UV for Genie & NuZar | RATK350GE |
| Super-Genie Series | 100 L Tank with Tank UV for Super-Genie | RATK100SE |
| | 350 L Tank with Tank UV for Super-Genie | RATK350SE |
| | 350 L Tank with Tank UV & Distribution System for Super-Genie | RATK350SP |
| Direct-Pure Series | 30 L PE Tank, w/3-stage level sensor | RATANK030 |
| | 60 L PE Tank, w/3-stage level sensor | RATANK060 |
| | 100 L PE Tank, w/3-stage level sensor | RATANK01H |
| | 350 L PE Tank, w/3-stage level sensor | RATANK03H |



Right water in Right Tank!

All rights reserved © 2023 RephiLe Bioscience, Ltd.
RephiLe, Genie, Super-Genie and NuZar are registered trademarks of
RephiLe Bioscience, Ltd.™ and ® may be omitted in this brochure.
All other trademarks mentioned are the property of their respective owners.

RephiLe Bioscience, Ltd.

Toll Free: +1-855-RephiLe (+1-855-737-4453)

E-mail: info@rephile.com



Literature: RFPRI612308

www.rephile.com