

Storage Tanks for Pure Water

Protect the quality of purified water based on the best proven technology & designs

A storage tank is an essential component in a water purification system and maintaining the purity of stored water is of great importance.

Rephile offers a series of high quality tanks (30 L, 60 L, 100L, 350 L) together with choices of accessories to provide reliable protection of purified water, which forms a solid base for all downstream applications of pure water.



Good Production Technique • Best Raw Material • Thoughtful Designs

Product Features

- High purity inert HDPE material. HDPE has little branching, making it stronger intermolecular forces and tensile strength, results in
 - Low extractable
 - Smooth surface characteristics
 - Opacity
 - Durability
- Opaque construction and smooth inner surface to minimize biofilm formation and algal growth
- No dead volume thanks to cylindrical shape and conical bottom design. Easy in emptying and cleaning
- Threaded lid for airtight closure, preventing air from entering inside the tank
- A vent filter to guard the water tank against particles and microbes from atmosphere. It contains
 - Soda lime in granular form, which removes carbon dioxide CO₂ from air and is known as “CO₂ scavenger”
 - Granular activated carbon or GAC, which removes organic matter from the air
 - 0.22 hydrophobic membrane, which removes air-borne bacteria
- Rectangular shape for spacing-saving solutions and easier ways to make a lab tidy and organized. Unique reinforcing-bar design to prevent deformation for 100 L & 350 L tanks
- Provision for easy cleaning and fully drainable



Conical Bottom Design

Storage Tanks for Pure Water

Storage tanks for Genie, NuZar and Super-Genie water systems

- Continuous liquid level sensor for exact measurement of water level at any point
- Overflow protection sensors managed by control console. Convenient and worry-free



Optional Accessories

- Compact design of UV sanitization module to effectively reduce bacterial proliferation inside the tank
- Distribution units with pump base in a stainless steel frame to distribute water to points of use
- Spray ball installation for efficient, effective and dependable cleaning



Mercury-free germicidal UVC LED lamp (265 nm) in tank sanitization module

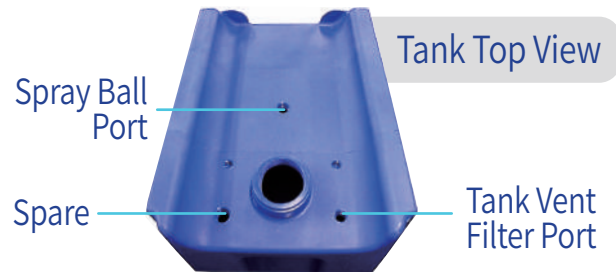

Storage tanks for Direct-Pure water systems

A storage tank for a Direct-Pure system uses a float sensor with programmed high/medium/low level cut-offs to guarantee the proper operation of the system, preventing overflow, low level or costly damage to a pump.



Stainless Steel Tank Level Sensor for 100 & 350 L reservoirs



Optional Accessories



Distribution Controller



Sanitization Module & 254 nm UV lamp

Specifications

30 / 60 / 100 / 350 L Storage Tanks

Size (cm/inch) Volume (liter)	W	D	H1	H2
30	34 / 13.4	45 / 17.7	66 / 25.9	61 / 24.0
60	34 / 13.4	45 / 17.7	90 / 35.4	85 / 33.5
100	56 / 22.0	27 / 10.6	148 / 58.3	137 / 53.9
350	56 / 22.0	72 / 28.3	148 / 58.3	137 / 53.9

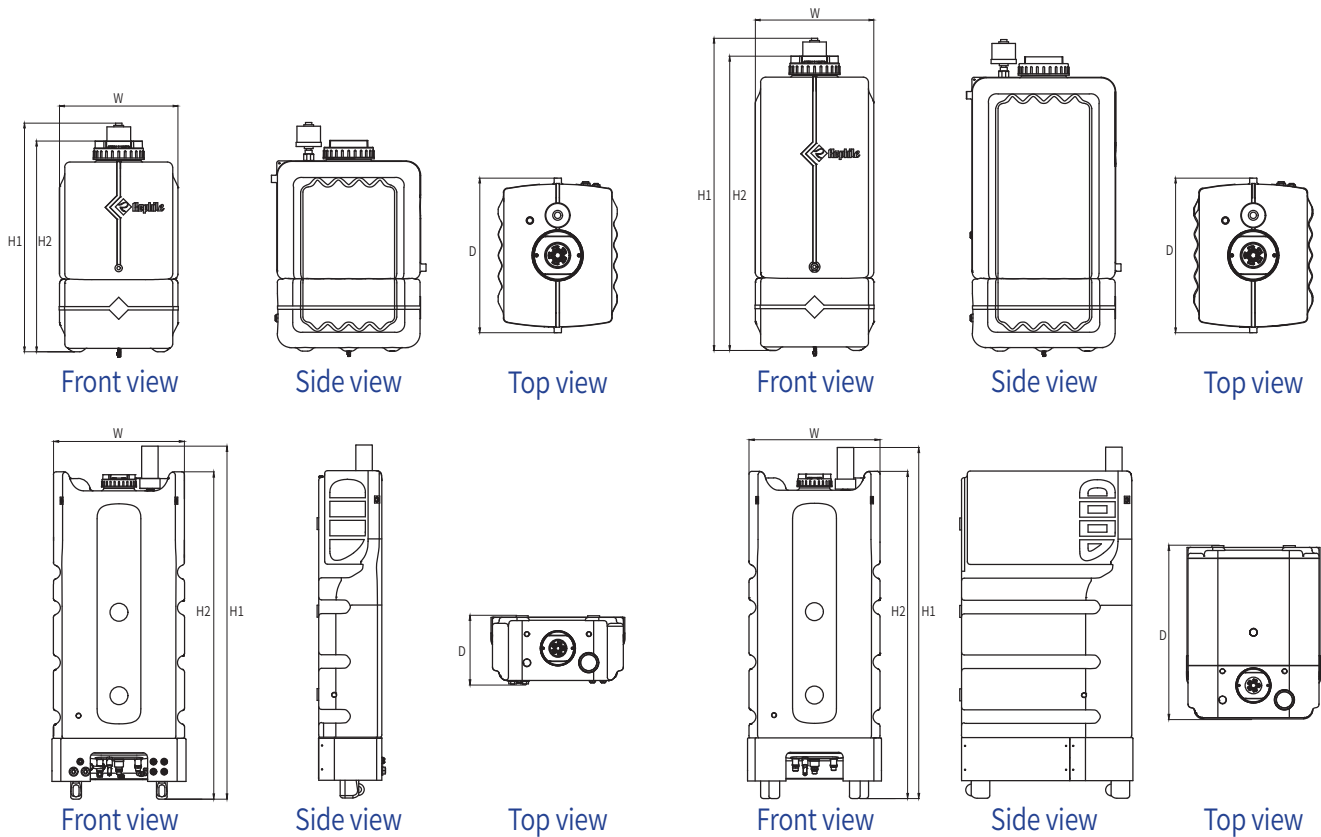

Weight of Empty Storage Tanks with Packing

Weight (kg/lb) Volume (liter)	For Genie & NuZar	For Super-Genie	For Direct-Pure
30	8.9 / 19.6	8.9 / 19.6	8.9 / 19.6
60	13.3 / 29.3	13.3 / 29.3	13.3 / 29.3
100	30 / 66.1	30 / 66.1	30 / 66.1
350	75 / 165.3	75 / 165.3	75 / 165.3
350 (with pump)	120 / 264.6	120 / 264.6	-

Storage Tanks for Pure Water

Tank Vent Filters



Applicable to 30 L / 60 L storage tanks (Genie, NuZar & Direct-Pure systems)
100 L (Genie & NuZar systems)

Applicable to 100 L & 350 L storage tanks (Direct-Pure & Super-Genie systems)



Ordering Info

	Description	Catalogue No.
Genie Series	30 L PE Tank, w/continuous level sensor & overflow sensor	RATK030L0
	60 L PE Tank, w/continuous level sensor & overflow sensor	RATK060L0
NuZar Series	100 L PE Tank, w/continuous level sensor & overflow sensor, for Genie systems	RATK100G0
	100 L PE Tank, w/continuous level sensor & overflow sensor, for Super-Genie systems	RATK100L0
Super-Genie Series	350 L PE Tank, w/continuous level sensor & overflow sensor	RATK350L0
	350 L PE Tank, w/continuous level sensor, sanitization module and pump base	RATK350LP
	30 L PE Tank, w/3-stage level sensor	RATANK030
Direct-Pure Series	60 L PE Tank, w/3-stage level sensor	RATANK060
	100 L PE Tank, w/3-stage level sensor	RATANK01H
	350 L PE Tank, w/3-stage level sensor	RATANK03H



Right water in Right Tank!

All rights reserved © 2022 RephiLe Bioscience, Ltd.
RephiLe, Genie, Super-Genie and NuZar are registered trademarks of RephiLe Bioscience, Ltd.™ and ® may be omitted in this brochure. All other trademarks mentioned are the property of their respective owners.

RephiLe Bioscience, Ltd.

Toll Free: +1-855-RephiLe (+1-855-737-4453)

E-mail: info@rephile.com



Literature: RFPRI612305

www.rephile.com