

Storage Tanks for Pure Water

Protect the quality of purified water based on the best proven technology & designs



A storage tank is an essential component in a water purification system and maintaining the purity of stored water is of great importance.



Rephile offers a series of high quality tanks (30 L, 60 L, 100L, 350 L) together with choices of accessories to provide reliable protection of purified water, which forms a solid base for all downstream applications of pure water.

Good Production Technique ● Best Raw Material ● Thoughtful Designs

Product Features

- High purity inert HDPE material. HDPE has little branching, making it stronger intermolecular forces and tensile strength, results in
 - Low extractable
 - Smooth surface characteristics
 - Opacity
 - Durability
- Opaque construction and smooth inner surface to minimize biofilm formation and algal growth
- No dead volume thanks to cylindrical shape and conical bottom design. Easy in emptying and cleaning
- Threaded lid for airtight closure, preventing air from entering inside the tank
- A vent filter to guard the water tank against particles and microbes from atmosphere. It contains
 - Soda lime in granular form, which removes carbon dioxide CO₂ from air and is known as "CO₂ scavenger"
 - Granular activated carbon or GAC, which removes organic matter from the air
 - 0.22 hydrophobic membrane, which removes air-borne bacteria
- Rectangular shape for spacing-saving solutions and easier ways to make a lab tidy and organized. Unique reinforcing-bar design to prevent deformation for 100 L & 350 L tanks
- Provision for easy cleaning and fully drainable

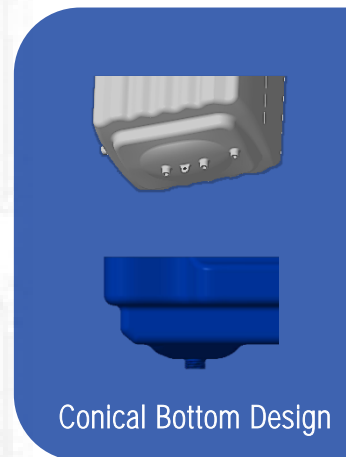

Conical Bottom Design

Storage tanks for Genie and Super-Genie water systems

- Continuous liquid level sensor for exact measurement of water level at any point
- Overflow protection sensors managed by control console. Convenient and worry-free

Optional accessories

- Compact design of UV sanitization module to effectively reduce bacterial proliferation inside the tank
- Distribution units with pump base in a stainless steel frame to distribute water to points of use
- Spray ball installation for efficient, effective and dependable cleaning



An Integral UV 254 nm Sanitization Module

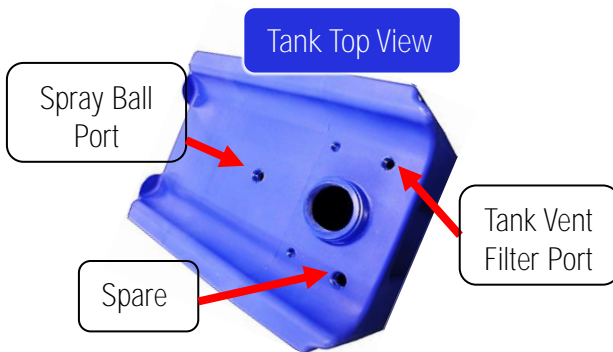

A complete water purification system

Storage tanks for Direct-Pure water systems

A storage tank for a Direct-Pure system uses a float sensor with programmed high/medium/low level cut-offs to guarantee the proper operation of the system, preventing overflow, low level or costly damage to a pump.

Stainless Steel Tank Level Sensor for 100 & 350 liters reservoirs

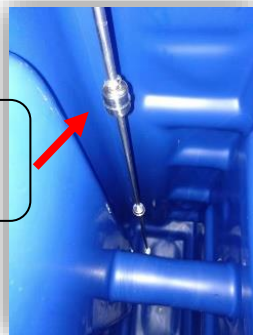

Optional accessories

Sanitization Module & 254 nm UV lamp



Distribution Controller



Specifications

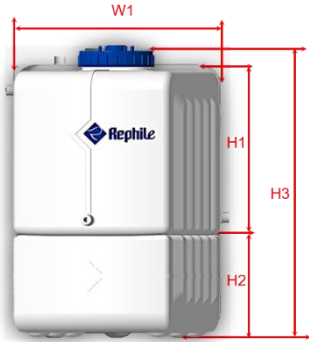

30-liter and 60-liter Storage Tanks

Volume \ Size (mm)	W1	W2	H1	H2	H3
30 L	413	340	336	207	576
60 L	413	340	576	207	816

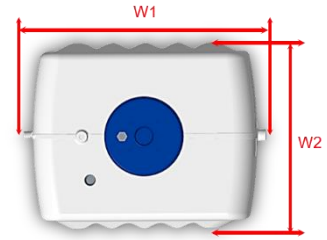

100-liter and 350-liter Storage Tanks

Volume \ Size (mm)	L	W	H1	H2	H3	Height
100 L	550	265	30	195	80	1319
350 L	550	715	35	195	80	1319

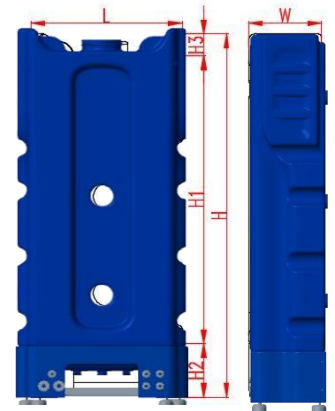

Weight of Empty Storage Tanks with Packing

Volume \ Weight (kg)	For Genie & Super-Genie	For Direct-Pure
30 L	8.9	8.9
60 L	13.3	13.3
100 L	30	30
350 L	75	75
350 L with pump	120	

Tank Vent Filters



Applicable to 30 L / 60 L storage tanks (both Genie and Direct-Pure systems) & 100 L (Genie systems)



Applicable to 100 L & 350 L storage tanks (Direct-Pure & Super-Genie systems)

Ordering info

	Description	Catalogue No.
Genie Series	30 L PE Tank, w/continuous level sensor & overflow sensor	RATK030LO
	60 L PE Tank, w/continuous level sensor & overflow sensor	RATK060LO
	100 L PE Tank, w/continuous level sensor & overflow sensor, for Genie systems	RATK100GO
Super-Genie Series	100 L PE Tank, w/continuous level sensor & overflow sensor, for Super-Genie systems	RATK100LO
	350 L PE Tank, w/continuous level sensor & overflow sensor	RATK350LO
	350 L PE Tank, w/continuous level sensor, sanitization module and pump base	RATK350LP
Direct-Pure Series	30 L PE Tank, w/3-stage level sensor	RATANK030
	60 L PE Tank, w/3-stage level sensor	RATANK060
	100 L PE Tank, w/3-stage level sensor	RATANK01H
	350 L PE Tank, w/3-stage level sensor	RATANK03H



RATK350LP

Right water in Right Tank!



All rights reserved © 2021 Rephile Bioscience, Ltd.
 Rephile is registered trademarks of Rephile Bioscience, Ltd.. TM and (R) may be omitted in this brochure.

Rephile Bioscience, Ltd.

Toll Free: +1-855-Rephile (+1-855-737-4453)

E-mail: info@rephile.com